

Type:

Model:

1X4 Field Tunable (watt and color temp.) Backlit LED Panel With Integrated Constant Power Battery Backup

ORDERING CODE:

487650-EM

SPECIFICATIONS

LED: 2835SMD LM80 certified,

WATTAGE: Select from 25W/30W/35W

COLOR TEMPERATURE: Select from 3000K/4000K/5000K

BEAM SPREAD: 120°

VOLTAGE: AC120-277V

PF: >0.92

DIMMING: 0-10V Dimming

DRIVER: External isolated LED driver (No-flicker)

WARRANTY: Five years.



DIMENSIONS:

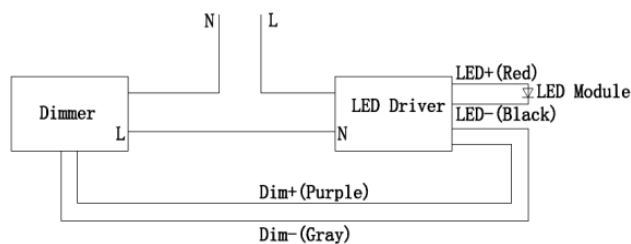
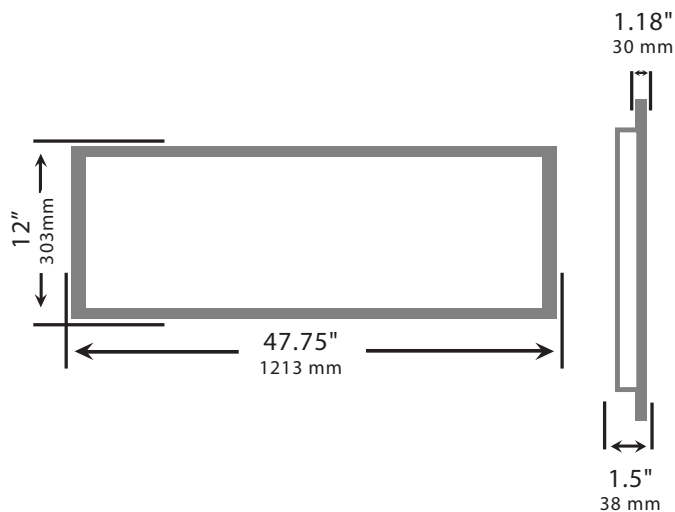

1x4 Field Tunable (watt and Color Temp.) Backlit LED Panel With Integrated Constant Power Battery Backup

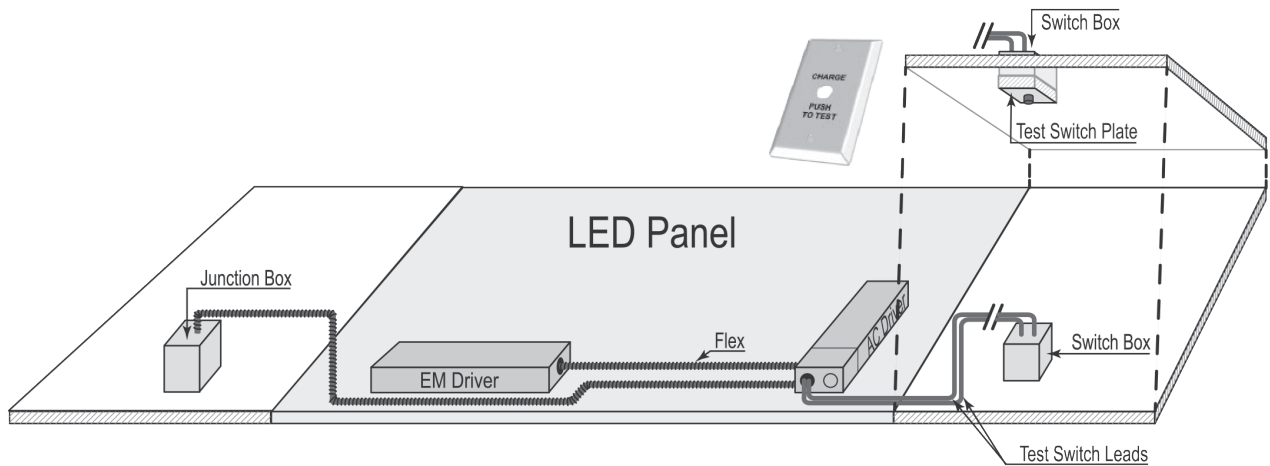

- Complies with NFPA Life Safety Code which requires at least 90 minutes of backup lighting following a power failure, with an average of 1 foot-candle. System provides a continuous level of illumination for more than 90 minutes.
- Contains a UL 924 compliant emergency lighting power supply system that eliminates the need for wiring to an external backup system.
- Push-button LED-illuminated test switch (supplied with labeled white mounting plate) enables easy compliance with scheduled testing requirements.
- System is fully charged in 24 hours.
- Protected from surges and overcurrent.
- Five-year warranty.
- UL-listed panel provides up to 130 lm/W efficacy. Please refer to the chart below.
- 0 to 10V dimming.

LED PANEL SPECIFICATIONS

Color Temp.	Efficacy	Wattage	Lumens
3K	110 LM/W	25W	2750 LM
		30W	3300 LM
		35W	3850 LM
4K	120 LM/W	25W	3000 LM
		30W	3600 LM
		35W	4200 LM
5K	130 LM/W	25W	3250 LM
		30W	3900 LM
		35W	4550 LM
With Battery Backup			
Color Temp.	Efficacy	Wattage	Lumens
3K	110 LM/W	7.8W	858 LM
4K	120 LM/W	7.8W	936 LM
5K	130 LM/W	7.8W	1014 LM

