

Type:

Model:

**2X4 Field Tunable (watt and color temp.) Backlit LED Panel With Integrated Constant Power Battery Backup**

**ORDERING CODE:**  
487652-EM

**SPECIFICATIONS**

**LED:** 2835SMD LM80 certified,

**WATTAGE:** Select from 30W/35W/40W

**COLOR TEMPERATURE:** Select from 3000K/4000K/5000K

**BEAM SPREAD:** 120°

**VOLTAGE:** AC120-277V

**PF:** >0.92

**DIMMING:** 0-10V Dimming

**DRIVER:** External isolated LED driver (No-flicker)

**WARRANTY:** Five years.



**DIMENSIONS:**

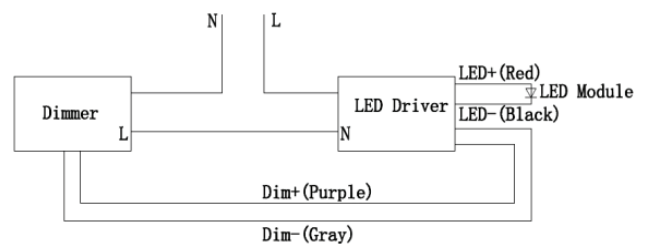
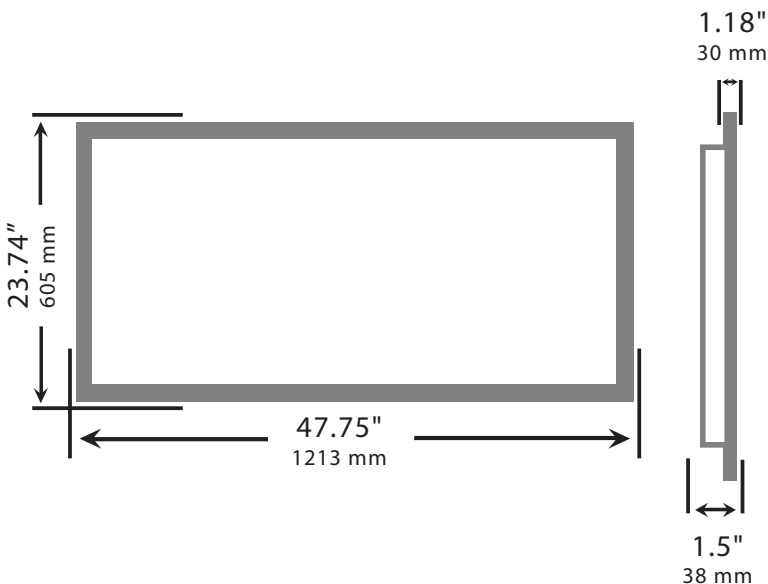

## 2x4 Field Tunable (watt and Color Temp.) Backlit LED Panel With Integrated Constant Power Battery Backup

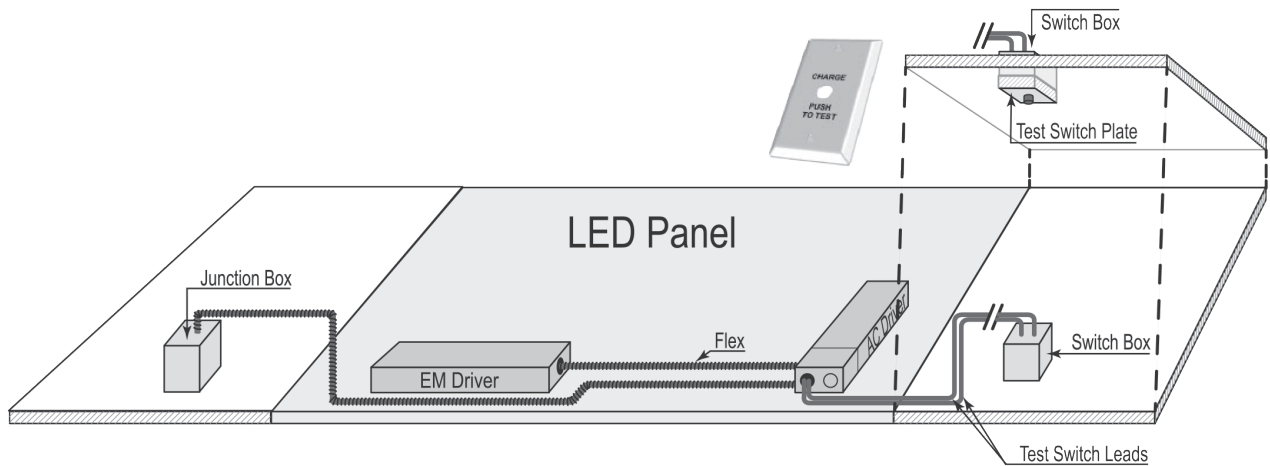

- Complies with NFPA Life Safety Code which requires at least 90 minutes of backup lighting following a power failure, with an average of 1 foot-candle. System provides a continuous level of illumination for more than 90 minutes.
- Contains a UL 924 compliant emergency lighting power supply system that eliminates the need for wiring to an external backup system.
- Push-button LED-illuminated test switch (supplied with labeled white mounting plate) enables easy compliance with scheduled testing requirements.
- System is fully charged in 24 hours.
- Protected from surges and overcurrent.
- Five-year warranty.
- UL-listed panel provides up to 130 lm/W efficacy. Please refer to the chart below.
- 0 to 10V dimming.

**LED PANEL SPECIFICATIONS**

Color Temp.	Efficacy	Wattage	Lumens
3K	110 LM/W	30W	3300 LM
		35W	3850 LM
		40W	4400 LM
4K	120 LM/W	30W	3600 LM
		35W	4200 LM
		40W	4800 LM
5K	130 LM/W	30W	3900 LM
		35W	4550 LM
		40W	5200 LM
With Battery Backup			
Color Temp.	Efficacy	Wattage	Lumens
3K	110 LM/W	10.7W	1177 LM
4K	120 LM/W	10.7W	1284 LM
5K	130 LM/W	10.7W	1391 LM

