

Type:

Model:

ENCLAVE Path Light Fixture 22"

ORDER CODE:

489909-22

SPECIFICATIONS

HOUSING:

Cast brass

FINISH:

Weathered brass. Custom powder coated colors available.

SOCKET/LAMP HOLDER:

One fixed ceramic bi-pin socket accepts bi-pin lamps with G4 or GY6.35 base.

LENS:

Tempered glass.

LAMP TYPE:

12V bi-pin. LED recommended. 30W halogen or 6W LED maximum.

MOUNTING:

Stake mount.



WIRING:

Pre-wired with 5' pigtail of 18/2 cable.

WARRANTY:

Lifetime.

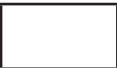
ARCHITECTURAL COLORS:

FINE TEXTURE WHITE		(489909-22-WH)
FINE TEXTURE SILVER		(489909-22-S)
FINE TEXTURE BLACK		(489909-22-BLK)



NOW OFFERED IN BLACK AS A STANDARD INVENTORY ITEM.

DIMENSIONS:

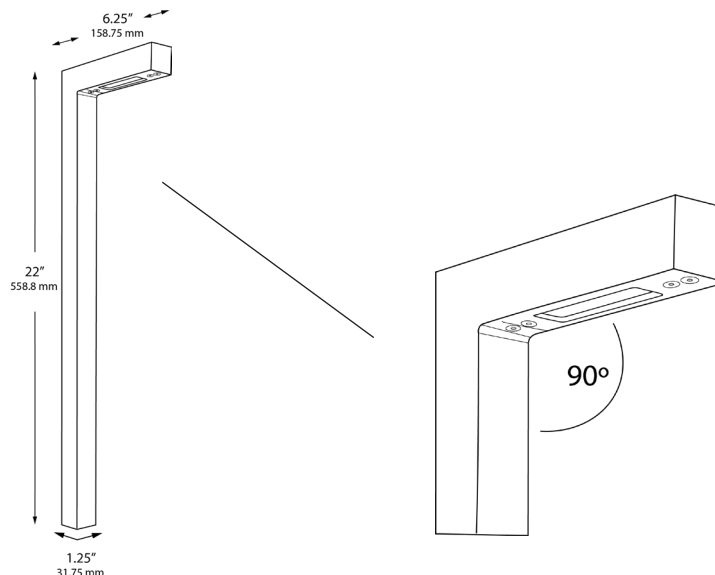

LED LAMP SPECIFICATIONS

LAMP TYPE:

Dauer encapsulated bi-pin with 5-year warranty.

COLOR TEMPERATURES:

2700K or 3000K. Decorative colors include amber, blue, green and red.

FIXTURE ORDERING INFORMATION

To order a lamped fixture with mounting options, select the appropriate choice from each column as in the following example:

EXAMPLE: 489909-22-4W-E-2700K-MS



FIXTURE	LAMP			MOUNTING
	WATTAGE	TYPE	COLOR TEMP.	
489909-22 489909-22-WH 489909-22-S 489909-22-BLK	2W	E Encapsulated bi-pin	2700K / 3000K	MS Composite stake (incl.) 490034 M3 Trident Heavy-Duty 3-Prong Stake 490036 PM Round pier mount 490057 MR Round tapered 3-hole surface mount 490048 MP PVC/Brass post stake 490037
	3W	E Encapsulated bi-pin	2700K / 3000K	
	3.3W	S SMD bi-pin	Amber / Blue / Green / Red	
	4W	E Encapsulated bi-pin	Amber	
	4W	E Encapsulated bi-pin	2700K / 3000K	
	4W	E Encapsulated bi-pin	2700K-HO / 3000K-HO	