

Type:

Model:

REGENT LED MR8 Path Light

ORDERING CODE:

489912

SPECIFICATIONS

HOUSING:

Cast brass fixtures. Adjustable shrouds with tension screws.

FINISH:

Weathered brass. Custom powder coated colors available.

SOCKET/LAMP HOLDER:

Fixed ceramic bi-pin sockets with stainless steel retaining springs.

LENS:

Clear tempered glass.

LAMP TYPE:

12V MR8. LED recommended. 35W halogen or 6W LED maximum.

MOUNTING:

Stem threaded with 1/2" NPT. Heavy-duty composite stake included. May be mounted into threaded hubs in junction boxes or mounting accessories.

WIRING:

Pre-wired with 5' pigtail of 18/2 cable.

WARRANTY:

Lifetime.



DIMENSIONS:

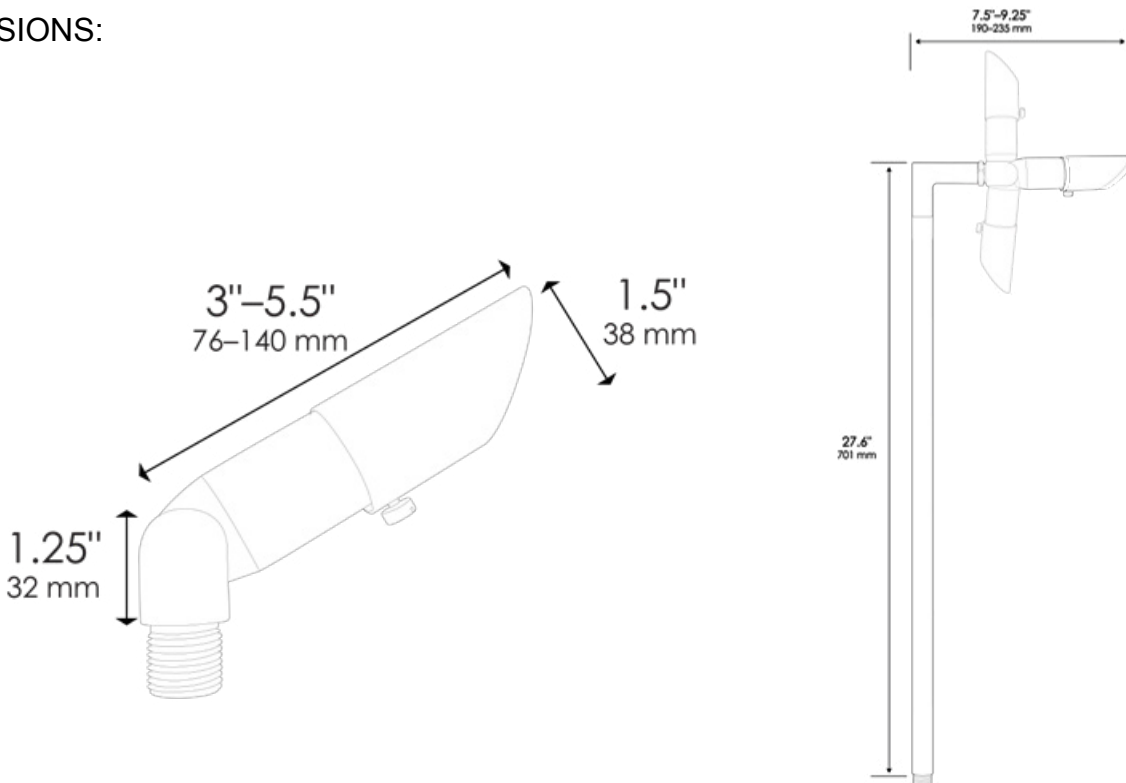

LED LAMP SPECIFICATIONS

LAMP TYPE:

12V Dauer MR8 lamp with 5-year warranty, suitable for enclosed luminaires.

OPTICS:

Integral optics providing available beam spreads from 30° to 100°.

COLOR TEMPERATURES:

Color temperature options MR8 available in 2700K and 3000K.



FIXTURE ORDERING INFORMATION

To order a lamped fixture with mounting options, select the appropriate choice from each column as in the following example:

EXAMPLE: 489912-2W-60-2700K-MS

FIXTURE	LAMP			MOUNTING
	WATTAGE	BEAM SPREAD	COLOR TEMP.	
489912	2W	30° / 60° / 100°	2700K	MS Composite stake (incl.) 490034 M3 Trident Heavy-Duty 3-Prong Stake 490036 PM Round pier mount 490057 MR Round tapered 3-hole surface mount 490048 MP PVC/Brass post stake 490037
	2.5W	38° / 60°	2700K / 3000K	