

Type:

Model:

## CHURCHILL Hardscape Fixture

**ORDERING CODE:**

490080

**SPECIFICATIONS**

**HOUSING:**

Cast brass.

**FINISH:**

Weathered brass. Custom powder coated colors available.

**LENS:**

Clear glass.

**SOCKET/LAMP HOLDER:**

Two fixed ceramic bi-pin sockets accept bi-pin lamps with G4 or GY6.35 bases.

**LAMP TYPE:**

12V bi-pin. LED recommended. Halogen 30W maximum or 6W LED maximum.

**MOUNTING:**

Brass mounting plates facilitate mounting under a hardscape cap or flush to a wall.

**WIRING:**

Pre-wired with 5' pigtail of 18/2 cable.

**WARRANTY:**

Lifetime.



**DIMENSIONS:**

*Under Cap Mount*

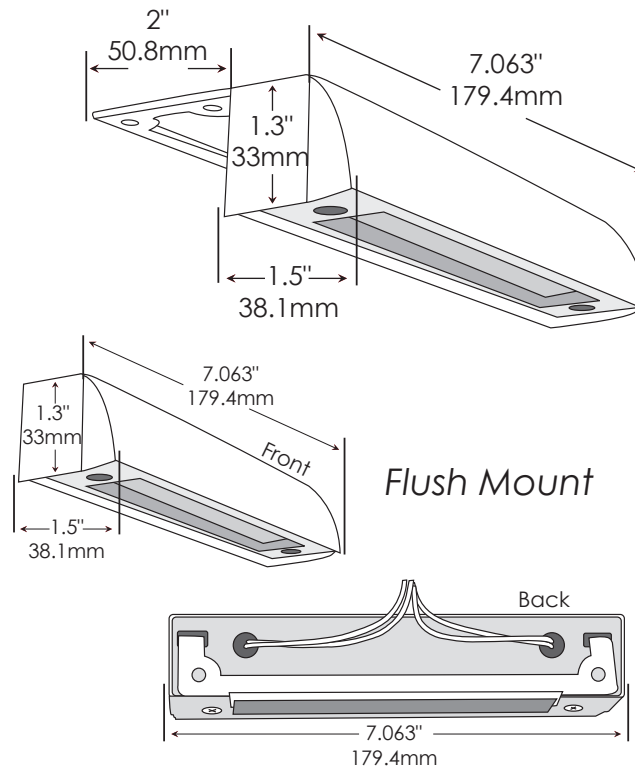

## LED LAMP SPECIFICATIONS

### LAMP TYPE:

Two 12V Dauer bi-pins with 5-year warranty, dimmable, and suitable for enclosed luminaires.

### COLOR TEMPERATURES:

Color temperature options provide the following qualities: 2700k or 3000K. Decorative color light options include amber, blue, green, and red.



## FIXTURE ORDERING INFORMATION

To order a lamped fixture with mounting options, select the appropriate choice from each column as in the following example:

EXAMPLE: 490080-4W-2700K

FIXTURE	LAMP	
	WATTAGE	COLOR TEMP.
490080	2W	2700K / 3000K
	3W	2700K / 3000K
	3.3W	Amber / Blue / Green / Red
	4W	Amber
	4W	2700K / 3000K

