

Type:

Model:

BRECKENRIDGE Marker Light Fixture

ORDERING CODE:
489992

SPECIFICATIONS

HOUSING:
Cast brass.

FINISH:
Weathered brass. Custom powder coated colors available.

SOCKET/LAMP HOLDER:
One ceramic G4 bi-pin socket with stainless steel retaining rings.

LENS:
Flat tempered glass.

LAMP TYPE:
12V MR8. LED recommended. 4W LED maximum.

MOUNTING:
Installs in-grade. 1-5/8" opening needed to insert PVC sleeve.
5.5" PVC sleeve included.

WIRING:
Pre-wired with 5' pigtail of 18/2 cable.

WARRANTY:
Lifetime



Driver-over rated at 4,400 lbs.

DIMENSIONS:

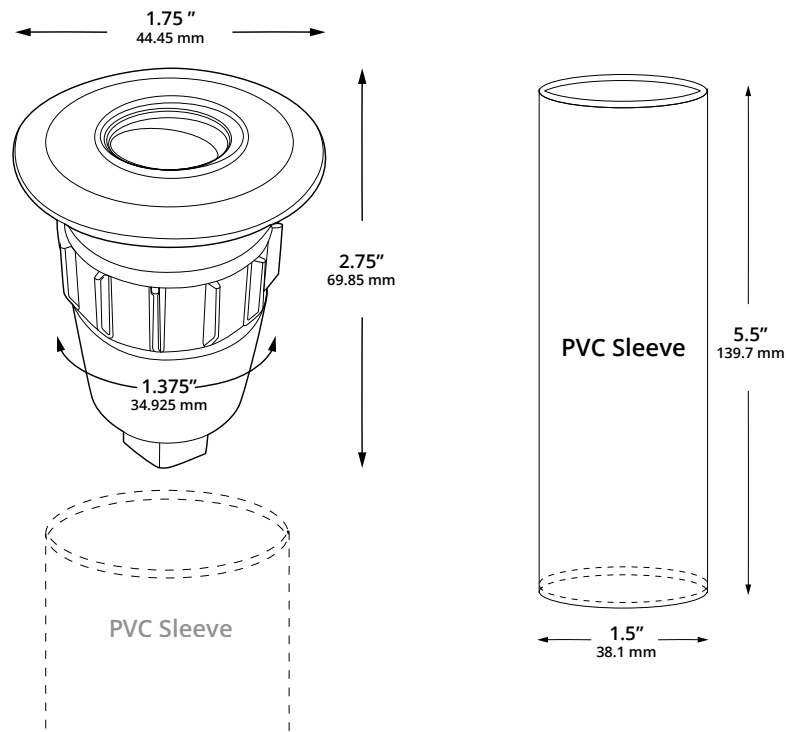

LED LAMP SPECIFICATIONS

LAMP TYPE:

12V Dauer MR8 lamp with 5-year warranty, suitable for enclosed luminaires.

OPTICS:

Integral optics providing available beam spreads from 30° to 100°.

COLOR TEMPERATURES:

Color temperature options MR8 available in 2700K or 3000K.



FIXTURE ORDERING INFORMATION

To order a lamped fixture with mounting options, select the appropriate choice from each column as in the following example:

EXAMPLE: 489992-2W-60-2700K-PV

FIXTURE	LAMP			MOUNTING
	WATTAGE	BEAM SPREAD	COLOR TEMP.	
489992	2W	30° / 60° / 100°	2700K / 3000K	PV PVC Sleeve (incl.)
	2.5W	38° / 60°	2700K / 3000K	