

Type:

Model:

**NOBLE Marker Light with Shroud**

**ORDERING CODE:**

489994

**SPECIFICATIONS**

**HOUSING:**

Cast brass.

**FINISH:**

Weathered brass. Custom powder coated colors available.

**SOCKET/LAMP HOLDER:**

One ceramic G4 bi-pin socket with stainless steel retaining rings.

**LENS:**

Flat tempered glass.

**LAMP TYPE:**

12V MR8. LED recommended. 4W LED maximum.

**MOUNTING:**

Installs in-grade. 1-5/8" opening needed to insert PVC sleeve.

5.5" PVC sleeve included.

**WIRING:**

Pre-wired with 5' pigtail of 18/2 cable.

**WARRANTY:**

Lifetime



**DIMENSIONS:**

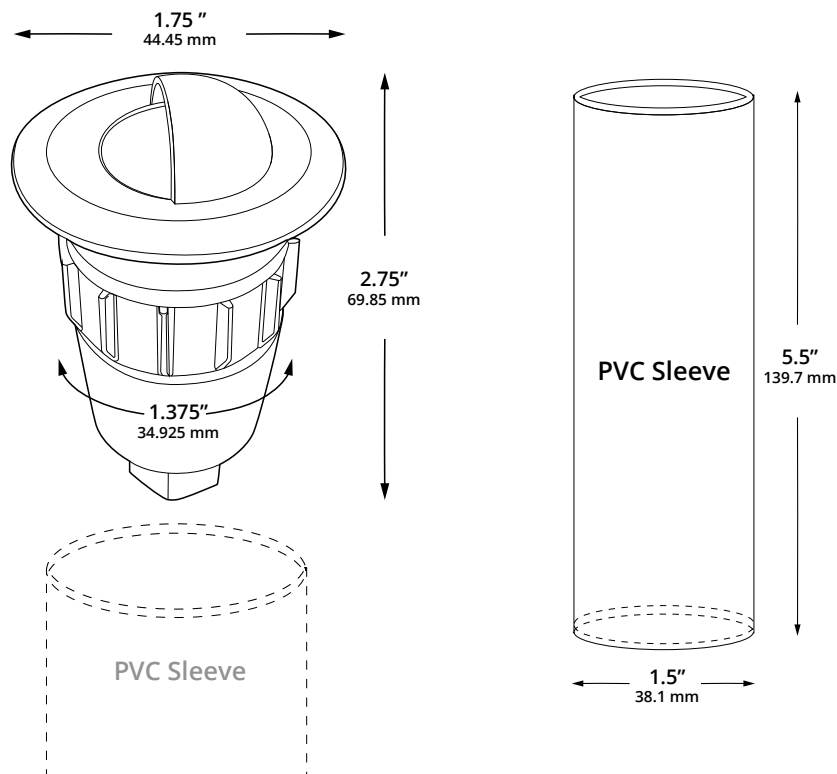

LED LAMP SPECIFICATIONS

**LAMP TYPE:**

12V Dauer MR8 lamp with 5-year warranty, suitable for enclosed luminaires.

**OPTICS:**

Integral optics providing available beam spreads from 30° to 100°.

**COLOR TEMPERATURES:**

Color temperature options MR8 available in 2700K.



**FIXTURE ORDERING INFORMATION**

To order a lamped fixture with mounting options, select the appropriate choice from each column as in the following example:

EXAMPLE: 489994-2W-60-2700K-PV

FIXTURE	LAMP			MOUNTING
	WATTAGE	BEAM SPREAD	COLOR TEMP.	
489994	2W	30° / 60° / 100°	2700K / 3000K	<b>PV</b> PVC Sleeve (incl.)
	2.5W	38° / 60°	2700K / 3000K	