

Type:

Model:

ENCLAVE Wildlife Safe Path Light 16"

ORDER CODE:

489909-16

SPECIFICATIONS

HOUSING:

Cast brass

FINISH:

Weathered brass. Custom powder coated colors available.

SOCKET/LAMP HOLDER:

One fixed ceramic bi-pin socket accepts bi-pin lamps with G4 or GY6.35 base.

LENS:

Tempered glass.

LAMP TYPE:

12V bi-pin. LED recommended. 30W halogen or 6W LED maximum.

MOUNTING:

Heavy-duty composite stake included.

WIRING:

Prewired with 5' pigtail of 18/2 cable.

WARRANTY:

Lifetime.

ARCHITECTURAL COLORS:

FINE TEXTURE WHITE		(489909-16-WH)
FINE TEXTURE SILVER		(489909-16-S)
FINE TEXTURE BLACK		(489909-16-BLK)



NOW OFFERED IN BLACK AS A STANDARD INVENTORY ITEM.

DIMENSIONS:

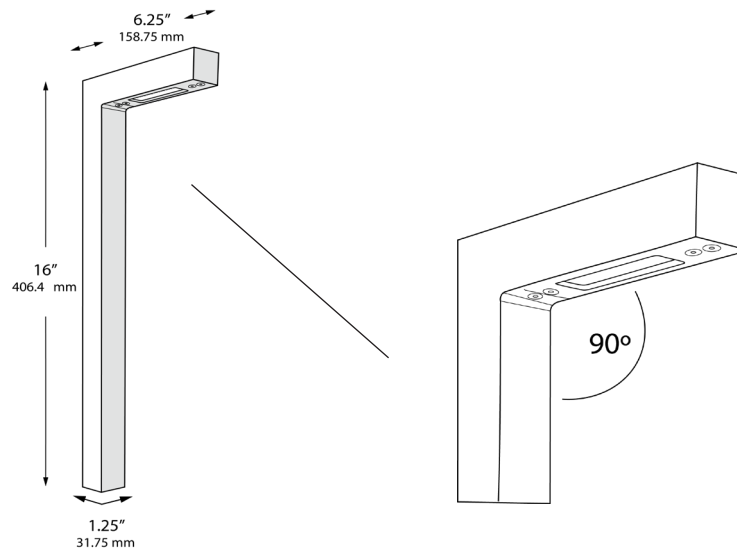

LED LAMP SPECIFICATIONS

LAMP TYPE:

Dauer encapsulated bi-pin with 5-year warranty.

COLOR TEMPERATURES:

Wildlife-approved, amber and red.



FIXTURE ORDERING INFORMATION

To order a lamped fixture, select the appropriate choice from each column as in the following example:

EXAMPLE: 489909-16-48712-WL-MR

FIXTURE	LAMP					MOUNTING
	ORDER NO.	COLOR	DESCRIPTION	WATTAGE	NANOMETER RANGE	
489909-16						MS Composite stake (incl.) 490034 M3 Trident Heavy-Duty 3-Prong Stake 490036 PM Round pier mount 490057 MR Round tapered 3-hole surface mount 490048 MP PVC/Brass post stake 490037
489909-16-WH	487123-WL	Amber-WL	Encap. Bi-pin G4	4w	585-595	
489909-16-S	487120-WL	Red-WL	Bi-pin G4	3w	610-645	
489909-16-BLK						