

Type:

Model:

**ENCLAVE Wildlife Safe Path Light 22"**

**ORDER CODE:**

489909-22

**SPECIFICATIONS**

**HOUSING:**

Cast brass

**FINISH:**

Weathered brass. Custom powder coated colors available.

**SOCKET/LAMP HOLDER:**

One fixed ceramic bi-pin socket accepts bi-pin lamps with G4 or GY6.35 base.

**LENS:**

Tempered glass.

**LAMP TYPE:**

12V bi-pin. LED recommended. 30W halogen or 6W LED maximum.

**MOUNTING:**

Stake mount.



**WIRING:**

Pre-wired with 5' pigtail of 18/2 cable.

**WARRANTY:**

Lifetime.

**ARCHITECTURAL COLORS:**

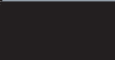
FINE TEXTURE WHITE		(489909-22-WH)
FINE TEXTURE SILVER		(489909-22-S)
FINE TEXTURE BLACK		(489909-22-BLK)



**NOW OFFERED IN BLACK AS A STANDARD INVENTORY ITEM.**

**DIMENSIONS:**

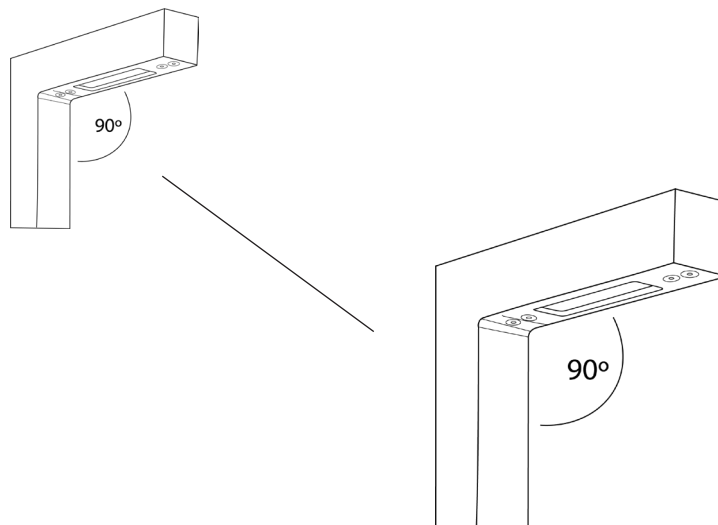

LED LAMP SPECIFICATIONS

**LAMP TYPE:**

Dauer encapsulated bi-pin with 5-year warranty.

**COLOR TEMPERATURES:**

Wildlife-approved, amber and red.

*These fixtures are only deemed wildlife approved if they utilize a wildlife-approved amber or red bulb as per the chart below.*

**FIXTURE ORDERING INFORMATION**

To order a lamped fixture with mounting options, select the appropriate choice from each column as in the following example:

EXAMPLE: 489909-22-487123-WL-MS



FIXTURE	LAMP					MOUNTING
	ORDER NO.	COLOR	DESCRIPTION	WATTAGE	NANOMETER RANGE	
489909-22						<b>MS</b> Composite stake (incl.) 490034 <b>M3</b> Trident Heavy-Duty 3-Prong Stake 490036 <b>PM</b> Round pier mount 490057 <b>MR</b> Round tapered 3-hole surface mount 490048 <b>MP</b> PVC/Brass post stake 490037
489909-22-WH	487123-WL	Amber-WL	Encap. Bi-pin G4	4w	585-595	
489909-22-S	487120-WL	Red-WL	Bi-pin G4	3w	610-645	
489909-22-BLK						