

Type:

Model:

MANCHESTER Aluminum Integrated LED Hardscape

ORDERING CODE:

490128-2700K

490128-3000K

SPECIFICATIONS

HOUSING:

Cast aluminum.

FINISH:

Architectural bronze. Custom powder coated colors available.

INTEGRATED LED:

3.49VA at 2700K; 3.64VA at 3000K color temperature. Dimmable.

LENS:

Factory installed clear lens plus three interchangeable, high-impact polycarbonate lenses included.

LIGHT OUTPUT:

Control your light output by swaping the following lenses:

- Factory installed clear lens: 313 lumens.
- Lightly frosted lens: Achieve 33% lumen reduction (208 lm).
- Heavier frosted lens: Achieve 50% lumen reduction (155 lm).
- Amber lens: Achieve 60% lumen reduction (125 lm) for a dramatic ultra-warm effect.

MOUNTING:

Three stainless steel mounting plates facilitate mounting under a hardscape cap or flush to a wall, or mount directly with screws.

WIRING:

Pre-wired with a 5' 18/2 cable.

WARRANTY:

Ten years.



DIMENSIONS:

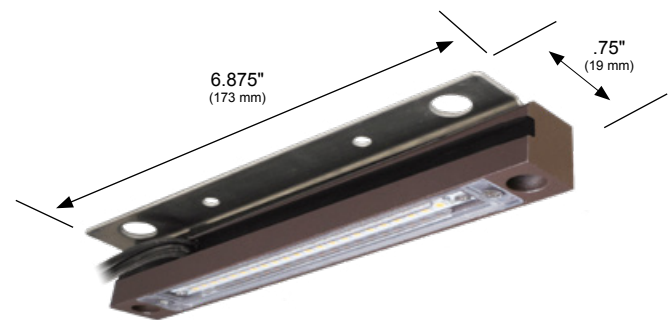
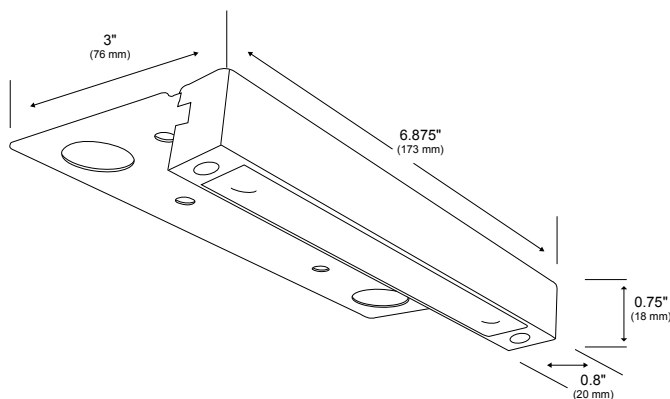

Includes three stainless steel mounting brackets: 2.5-inch and .75-inch brackets shown above for horizontal attachment, and a bracket for wall-mounting flush to a vertical surface as shown below. Can also be mounted under a surface without a bracket by inserting screws (not included) through the fixture's two screw holes, as shown below left.

