

Type:

Model:

ANDROS LED Bi-Pin Path Light Fixture

ORDERING CODE:
490017

SPECIFICATIONS

HOUSING:
Cast brass.

FINISH:
Weathered brass. Custom powder-coated colors available.

LENS:
Clear polycarbonate.

SOCKET/LAMP HOLDER:
One fixed ceramic bi-pin socket in stem accepts bi-pin lamps with G4 or GY6.35 bases.

LAMP TYPE:
12V bi-pin. LED recommended. Halogen 35W maximum or 6W LED maximum.

MOUNTING:
1/2" NPT. Heavy-duty composite stake included with stem. May be mounted into threaded hubs in junction boxes or other mounting accessories.

WIRING:
Pre-wired with 5' pigtail of 18/2 cable.

WARRANTY:
Lifetime.



The Andros path light features an 8.5" diameter cast brass hat. Its underside is a powder-coated reflective white surface.

DIMENSIONS:

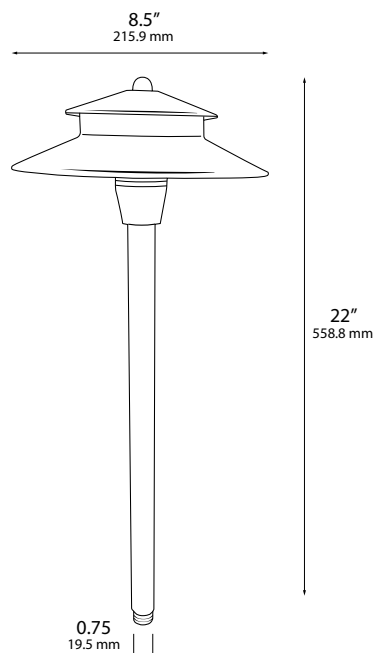

LED LAMP SPECIFICATIONS

LAMP TYPE:

Dauer encapsulated bi-pin with 5-year warranty.

COLOR TEMPERATURES:

2700K or 3000K. Decorative colors include amber, blue, green and red.
Wildlife-approved, amber and red.



FIXTURE ORDERING INFORMATION

To order a lamped fixture with mounting options, select the appropriate choice from each column as in the following example:

EXAMPLE: 490017-490025-4W-E-2700K-MS

FIXTURE	STEM	LAMP			MOUNTING
		WATTAGE	TYPE	COLOR TEMP.	
490017	490025 (10")	2W	E Encapsulated bi-pin	2700K / 3000K	MS Composite stake (incl.) 490034 M3 Trident Heavy-Duty 3-Prong Stake 490036 PM Round pier mount 490057 MR Round tapered 3-hole surface mount 490048 MP PVC/Brass post stake 490037
		3W	E Encapsulated bi-pin	2700K / 3000K	
	490023 (16")	3.3W	S SMD bi-pin	Amber / Blue / Green / Red	
		4W	E Encapsulated bi-pin	2700K / 3000K	
		4W	E Encapsulated bi-pin	Amber	
	490026 (18")	4W	E Encapsulated bi-pin	2700K-HO / 3000K-HO	