

Type:

Model:

## DUNES Marker Light with Shroud

**ORDERING CODE:**

489881-2700K  
489881-3000K

**SPECIFICATIONS**

**HOUSING:**

316 marine grade stainless steel.

**FINISH:**

Polished stainless steel.  
Custom powder-coated colors available.

**LENS:**

Flat tempered glass lens with shrouded top.

**INTEGRATED LED:**

1W. 12V. 28 lumens. 1.64 VA at 3000K. 80 CRI.

**MOUNTING:**

Installs in-grade. 1-9/16" opening needed to insert PVC sleeve.

PVC sleeve sold separately. Available in 12" (489889-12)  
and 6" (489889-6) heights.

**WIRING:**

Pre-wired with 5' pigtail of 18/2 cable.

**WARRANTY:**

Ten years.



### DIMENSIONS:

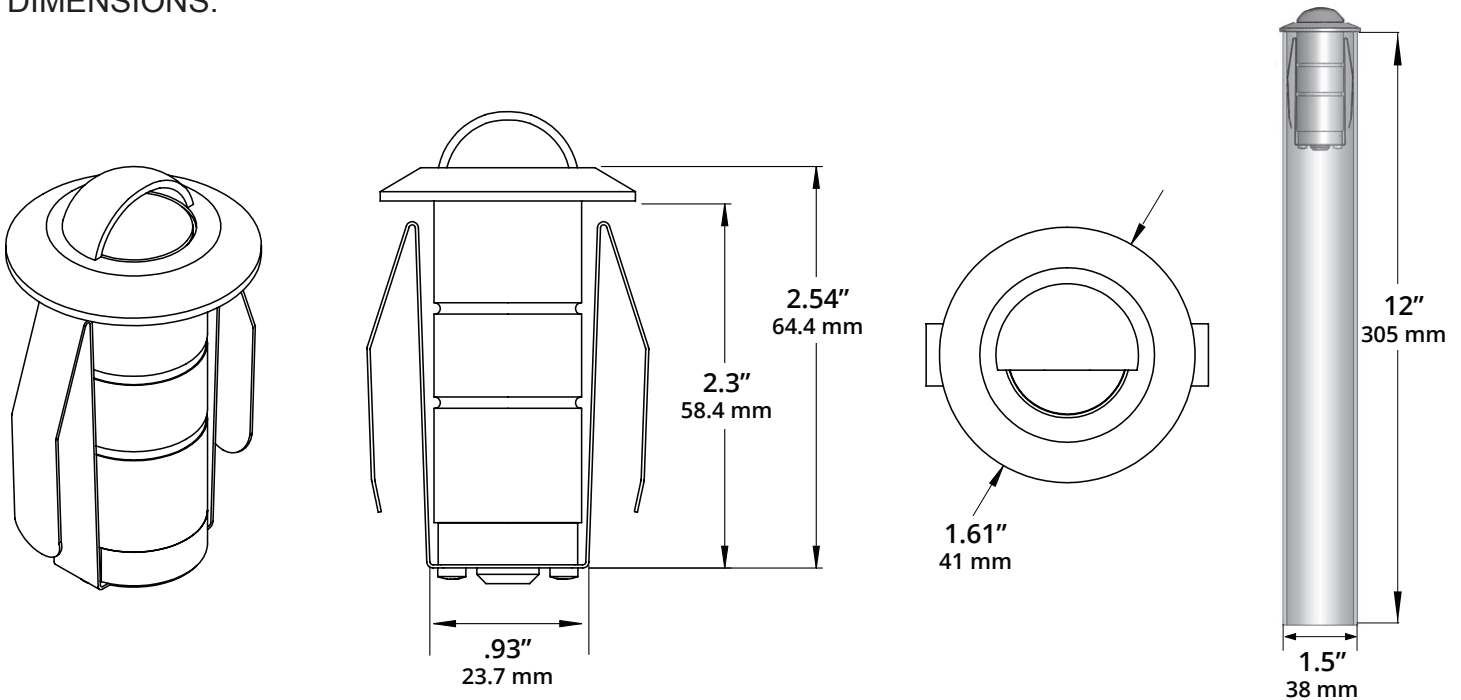

*PVC sold separately.  
Available in 12" and 6" heights.*