

Type:

Model:

WYNN Marker Light with Rock Guard

ORDERING CODE:

489882

SPECIFICATIONS

HOUSING:

304 grade stainless steel.

FINISH:

Polished stainless steel.

Custom powder-coated colors available.

LENS:

Flat tempered glass lens.

INTEGRATED LED:

1W. 12V. 27 lumens. 1.63 VA at 3000K. 80 CRI.

MOUNTING:

Installs in-grade. PVC sleeve sold separately.

Offered in 12" and 6".

WIRING:

Pre-wired with 5' pigtail of 18/2 cable.

WARRANTY:

Ten years.



Driver-over rated at 4,400 lbs.

DIMENSIONS:

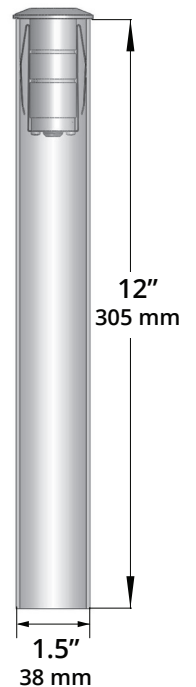
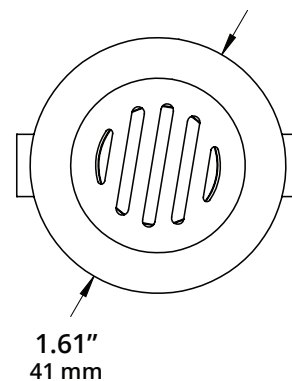
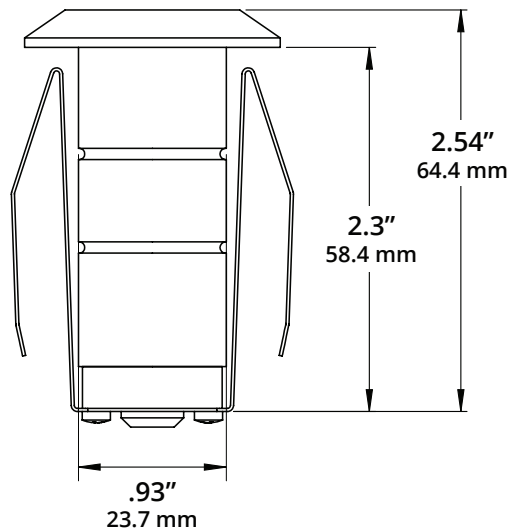
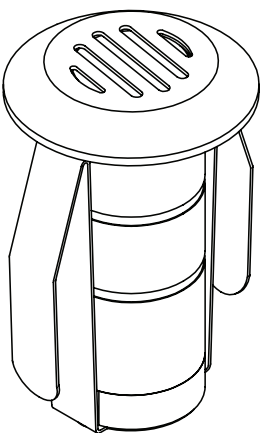

*PVC sold separately.
Available in 12" and 6" heights.*