

Type:

Model:

WYNN Marker Light with Rock Guard

ORDERING CODE:

489882-2700K
489882-3000K

SPECIFICATIONS

HOUSING:

316 marine grade stainless steel.

FINISH:

Polished stainless steel.
Custom powder-coated colors available.

LENS:

Flat tempered glass lens.

INTEGRATED LED:

1W. 12V. 27 lumens. 1.63 VA at 3000K. 80 CRI.

MOUNTING:

Installs in-grade. 1-9/16" opening needed to insert PVC sleeve.

PVC sleeve sold separately. Available in 12" (489889-12)
and 6" (489889-6) heights.

WIRING:

Pre-wired with 5' pigtail of 18/2 cable.

WARRANTY:

Ten years.



Driver-over rated at 4,400 lbs.

DIMENSIONS:

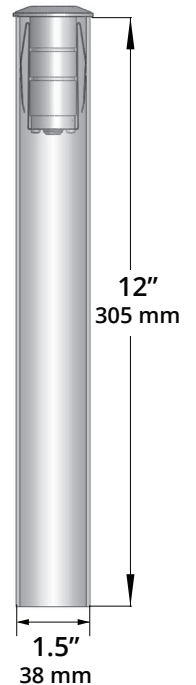
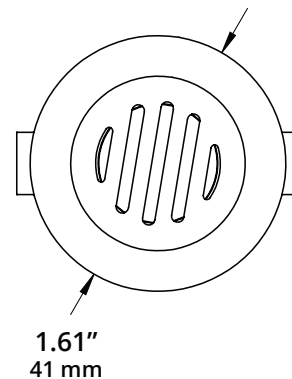
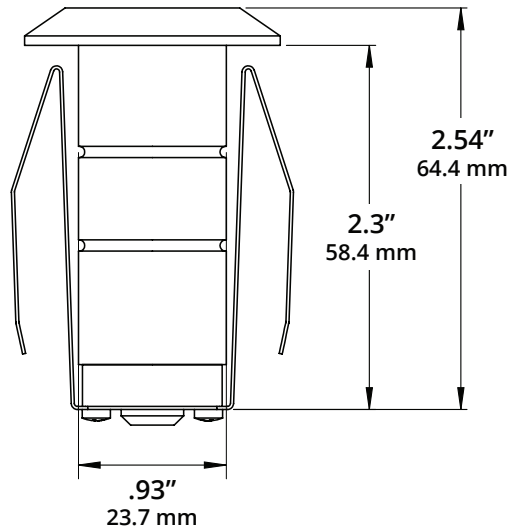
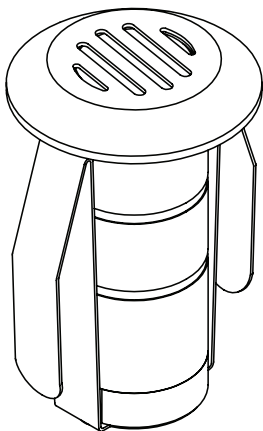

PVC sold separately.
Available in 12" and 6" heights.