



PRODUCT OVERVIEW/DFLL-217

These LED lights have transformed the landscape lighting environment. Utilizing performance optics and long lasting driver, these landscape lights will last for years to come. With various optical lenses, this luminaire can provide a narrow beam or wide beam, allowing the fixture to fit into any environment. Optional mounting and Kelvin color* with adder.



KEY FEATURES

LISTING

- UL- and CUL-listed for wet locations

HOUSING

- Die-cast aluminium housing

FINISH

- UV stabilized powder coated finish

LENS

- Integral glare shield and tempered glass

OPTIONS

- Versatile mounting choices
- Various optical lenses available
- Finish - Bronze/Verde Green/Black

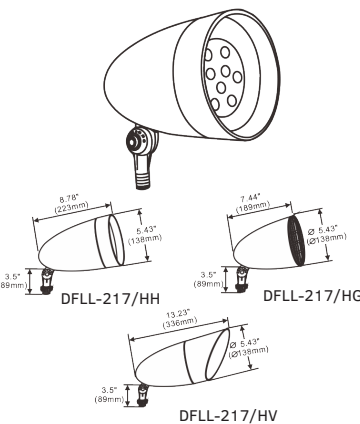

Model No.	DFLL-217/HH	DFLL-217/HG***	DFLL-217/HV***
System watts	20		
Lumen Output	2100 lm**		
Color	5000K		
MA	480MA		
Input Voltage	120-277V		
CRI	70+		
Starting Temp	-40°C		
Equivalent	100W MH		

* Different LED Kelvin temperature available with 4-6 week lead time. Please call for a quote.

** DISCLAIMER: This test report was produced in accordance with IES LM-79 photometric testing protocol for luminaires, using a single representative test fixture.

Actual production units may vary from the values reported here by up to +10%.



Available Options DFL-226E PVC Pipe DFL-226E Electrical Plate