



DFLL-226E

## PRODUCT OVERVIEW/DFLL-226E

These LED lights have transformed the landscape lighting environment. Utilizing performance optics and long lasting driver, these landscape lights will last for years to come. With various optical lenses, this luminaire can provide a narrow beam or wide beam, allowing the fixture to fit into any environment. Optional mounting and Kelvin color\* with adder.



## KEY FEATURES

### LISTING

- UL- and CUL-listed for wet locations

### HOUSING

- Die-cast aluminium housing

### FINISH

- UV stabilized powder coated finish

### LENS

- Integral glare shield and tempered glass

### OPTIONS

- Versatile mounting choices
- Various optical lenses available
- Finish - Bronze/Verde Green/Black

## SPECIFICATION

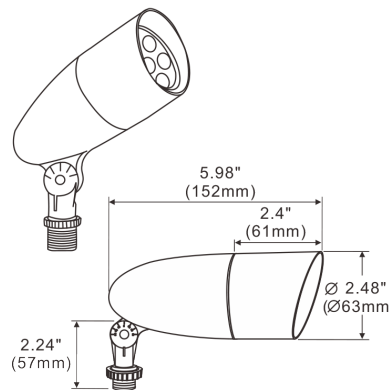

Model No.	DFLL-226E
System watts	5
Lumen Output	525 lm**
Color	5000K
MA	330MA
Input Voltage	120~240V
CRI	70+
Starting Temp	-40°C
Equivalent	50W MH



**Available Options** DFLL-226E PVC Pipe DFLL-226E Electrical Plate

\* Different LED Kelvin temperature available with 4-6 week lead time. Please call for a quote.

\*\* DISCLAIMER: This test report was produced in accordance with IES LM-79 photometric testing protocol for luminaires, using a single representative test fixture.

Actual production units may vary from the values reported here by up to +10%.