

Type:

Model:

**QUATTRO INTEGRATED
Path Light Fixture 24"**

ORDER CODE:
489162-2700K-BLK
489162-3000K-BLK

SPECIFICATIONS

HOUSING:

Aluminum

FINISH:

Black powder coat. Other custom powder coated colors available.

INTEGRATED LED:

2W, 3.40VA, 2700K and 3000K. 110° beam spread. 205lm. 80 CRI.

LENS:

Tempered glass.

MOUNTING:

Stake mount.

WIRING:

Pre-wired with 5' pigtail of 18/2 cable.

WARRANTY:

Ten years.

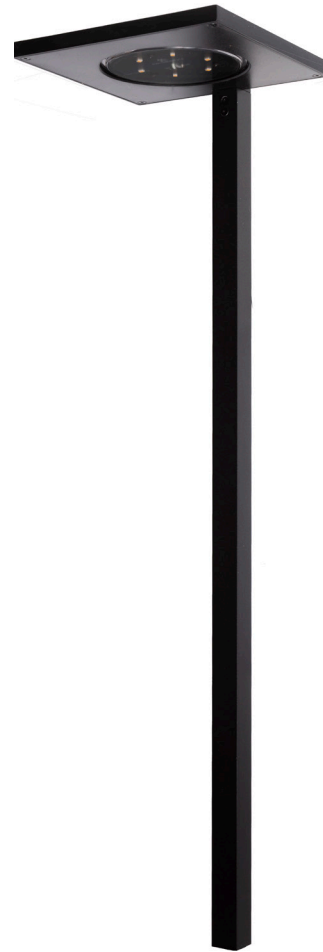

DIMENSIONS:

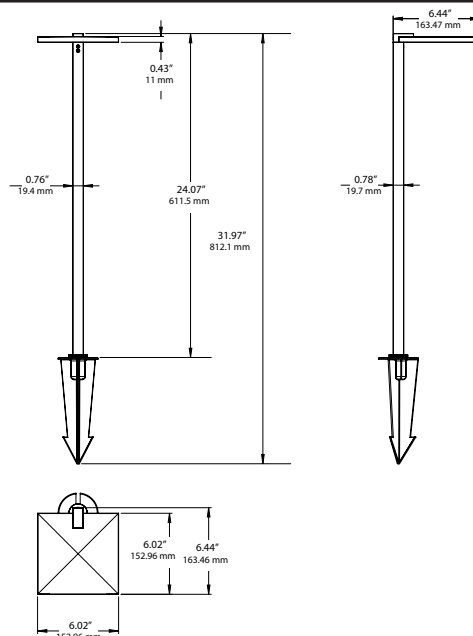

LED LAMP SPECIFICATIONS

INTEGRATED LED:

2W, 3.40VA, 2700K and 3000K. 110° beam spread. 205lm. 80 CRI.

COLOR TEMPERATURES:

2700K or 3000K.



FIXTURE ORDERING INFORMATION

To order a lamped fixture with mounting options, select the appropriate choice from each column as in the following example:

EXAMPLE: 489162-2700K-BLK-MS

CODES	WATTAGE	VOLTS	BEAM SPREAD	COLOR TEMP	LUMENS	EFFICACY	CRI	MOUNTING
489162-22-2700K	2W	12V	110°	2700K	205lm	102.5lm	80	MS Composite stake (incl.) 490034 M3 Trident Heavy-Duty 3-Prong Stake 490036 PM Round pier mount 490057 MR Round tapered 3-hole surface mount 490048 MP PVC/Brass post stake 490037
489162-22-3000K	2W	12V	110°	3000K	205lm	102.5lm	80	